



Development and Performance Assessment of Real-time Rotational Speed Measurement System for Agricultural Application

Aman Mahore ^{a*}, Mohit Kumar ^a, H. L. Kushwaha ^b,
Mukesh Kumar Choudhary ^b, Rohit Nalawade ^a
and Abhishek Patel ^a

^a ICAR-CIAE, Nabi Bagh, Bhopal-462038, India.

^b ICAR-IARI, New Delhi-110012, India.

Authors' contributions

This work was carried out in collaboration among all authors. All authors read and approved the final manuscript.

Article Information

DOI: 10.9734/IJPSS/2023/v35i42798

Open Peer Review History:

This journal follows the Advanced Open Peer Review policy. Identity of the Reviewers, Editor(s) and additional Reviewers, peer review comments, different versions of the manuscript, comments of the editors, etc are available here: <https://www.sdiarticle5.com/review-history/97087>

Original Research Article

Received: 29/12/2022

Accepted: 01/03/2023

Published: 06/03/2023

ABSTRACT

Rotational speed is one of the most important parameters in the performance of any system. It becomes more vital when the rotational speed measurement is required on real-time basis. Measurement of rotational speed has a crucial role in automation of agricultural machineries for various purposes. The existing real-time speed measurement systems are susceptible to the varying working environment. Therefore, it was necessary to study the performance of available sensor. In this study four different sensors (inductive proximity, Infrared (IR), Hall effect and optical proximity sensors) were tested in three different working environments (indoor, outdoor and outdoor dusty condition) for two different spacings (2 and 5 mm) between sensors and target. A

*Corresponding author: E-mail: aman.mahore.95@gmail.com;

laboratory setup was developed to test the performance of the sensors in terms of percentage deviation in rotational speeds measurement compared to actual values. The values were recorded in Secure Digital (SD) card and analysed using full factorial design. The means of the different levels were compared using Tukey's (b) method. There was significant difference in sensor response for different conditions. The percentage of deviation in speed for Hall effect, inductive proximity, IR and optical proximity sensors varied from 0.55 to 1.03, 1.20 to 32.29, 21.37 to 100.00 and 35.18 to 99.98%, respectively. The study concluded that the Hall effect sensor was more suitable for rotational speed measurement than the other sensors without being affected by working environment.

Keywords: RPM measurement; dust condition; hall effect sensor; Inductive proximity sensor; IR sensor; optical proximity sensor.

1. INTRODUCTION

Rotational speed measurement plays a critical role in automation of agricultural machineries for various operations such as tillage, sowing, inter-cultural operations and harvesting. In case of agriculture field, the traction is the most important factor affecting the performance of machines. The traction is generated due to soil and tyre interaction. The traction is affected by wheel slip, Soil moisture, normal load on wheel and tyre inflation pressure. Excessive slip during the field operation reduces the effective field capacity as well as life of traction wheel due to wear and tear. The wheel slip also affects the soil compaction [1]. It has been reported that the tractive efficiency is maximum when wheel slip is in the range of 8 and 15% [2]. Thus, measurement of wheel slip is essential for achieving the required efficiency of the machines [3]. The measurement of wheel slip requires the rotational speed of the traction device. There are challenges in real-time measurement of rotational speed while operating the machine in field conditions due to uneven field conditions, extreme environments and unavailability of suitable instruments. Therefore, there was a need to develop a robust system that can measure and record the rotational speed in real-time with high accuracy and precision. Studies had been carried out to determine the rotational speeds by measuring the pulse frequency. The common pulse generation methods are interrupter, optical, inductive, reluctance, and capacitive type but many of them are least reliable in field condition [4]. There are many sensors available for measurement of rotational speed on real-time basis used in industries or in controlled environment [5-8]. However, agricultural field work namely tillage, sowing,

harvesting and inter-cultural operations has a large varying working environment which may affect performance of the sensors. The real-time measurement of rotational speed requires a suitable sensor that can work satisfactorily in these varied conditions. Therefore, the behavior of any sensor to such conditions for the rotational speed measurement needs to be assessed before its application.

Keeping in view, the importance of real-time rotational speed measurement, several attempts had been made by various researchers to measure this parameter. The different techniques used for real-time measurement of rotational speed were purpose specific and in controlled conditions. Hence, there was a need to test the behavior of different sensors for rotational speed measurement in different working conditions. In this study performance of four different sensors were assessed in varying working environment and a suitable sensor was selected that can perform the required function in different working environment without affecting its performance.

2. MATERIALS AND METHODS

A laboratory setup was developed to test the sensors for rotational speed measurement in different working environment and distance between sensor and target. Four different sensors i.e., inductive proximity, IR, Hall effect and optical proximity were selected for the study based on the available literature (Table 1) [9-11]. The effects of working environment and distance between sensor and target on the performance of sensor were assessed. The performance of the sensor was assessed in terms of percentage deviation in speed compare to the actual speed.

Table 1. Properties and comparison of four sensors

Properties	Inductive Proximity Sensor	Optical Proximity Sensor	Infra-red Sensor	Hall Effect Sensor
Operating Voltage	5-40 VDC	5-35 VDC	5 VDC	4.5-24 VDC
Maximum Load Current	300 mA	300 mA	20 mA	25 mA
Sensing range	8 mm	300 mm adjustable	200 mm adjustable	Based on magnet strength
Sensing type	Metal in sensing range	Reflection from surface	Reflection from surface	Magnets
References	[2,12]	[11]	[9,13]	[10,14,15]

Laboratory setup: It consisted of a stepper motor platform, rotating disc, sensor mounting bracket, electric circuitry to operate motor at different speeds and recording unit. A mounting stand was fabricated to place various component of the setup (Fig. 1). Stepper motor (Nema 17, 4.2 kg.cm, 1.8° angular precision) was provided to rotate the disc over which magnets were stacked as the target to be sensed by each sensor. The rotating disc was 3D printed having 195 mm diameter mounted on stepper motor shaft (4.9 mm diameter) with the help of grub screw. A sensor mounting frame for all four sensors was 3D printed to position the sensors facing target to measure the rotational speed. The Stepper motor was powered by 12 V DC supply and speed was controlled with the help of stepper driver (A4988) and Arduino Uno (AtMega328P). The speed of stepper motor was varied from 10 to 390 rpm. The recording unit consisted of Arduino Mega (AtMega2560), SD card module, real-time clock (RTC), I²C type

liquid crystal display (LCD) and voltage converter [16,17].

Electrical circuitry: All the four sensors were connected to interrupt pin (digital pins 2, 3, 18 and 19) of microcontroller (AtMega2560) to detect the high values (1) for every interruption in the signal. The circuit was powered using 12 V DC power supply through voltage converter that steps down the voltage to 5 V DC. The readings of the sensors were recorded in recording unit. The recording units was developed using microcontroller, SD card module, Real-time Clock (RTC) module, digital display (16x2 I²C) and voltage converter (Fig. 2). SD card module was connected to digital pins 50, 51, 52 and 53 of microcontroller. The RTC was interfaced to I²C along with Liquid Crystal Display (LCD) having their unique identification values. All the components were supplied 5 V power supply from Arduino board.

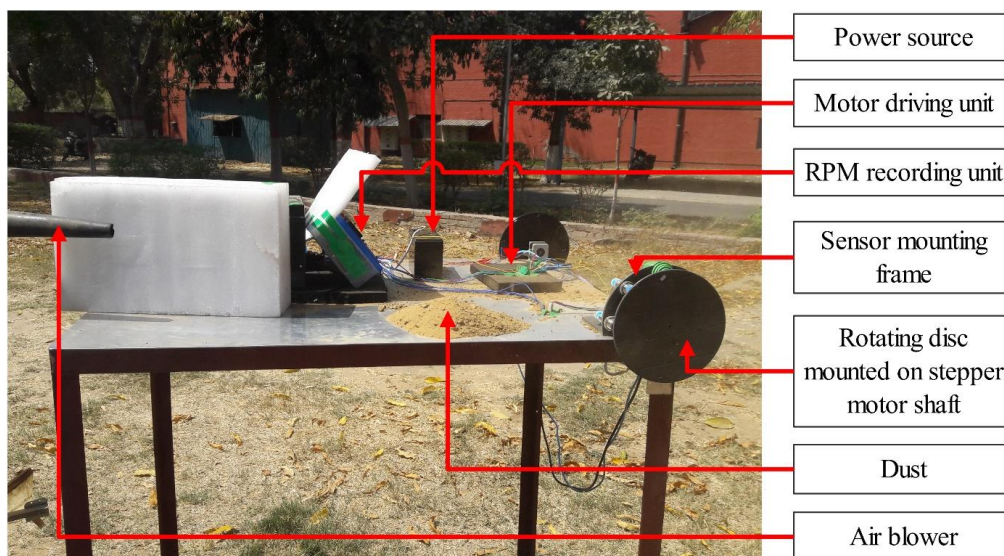

Fig. 1. Experimental setup in outdoor dusty condition

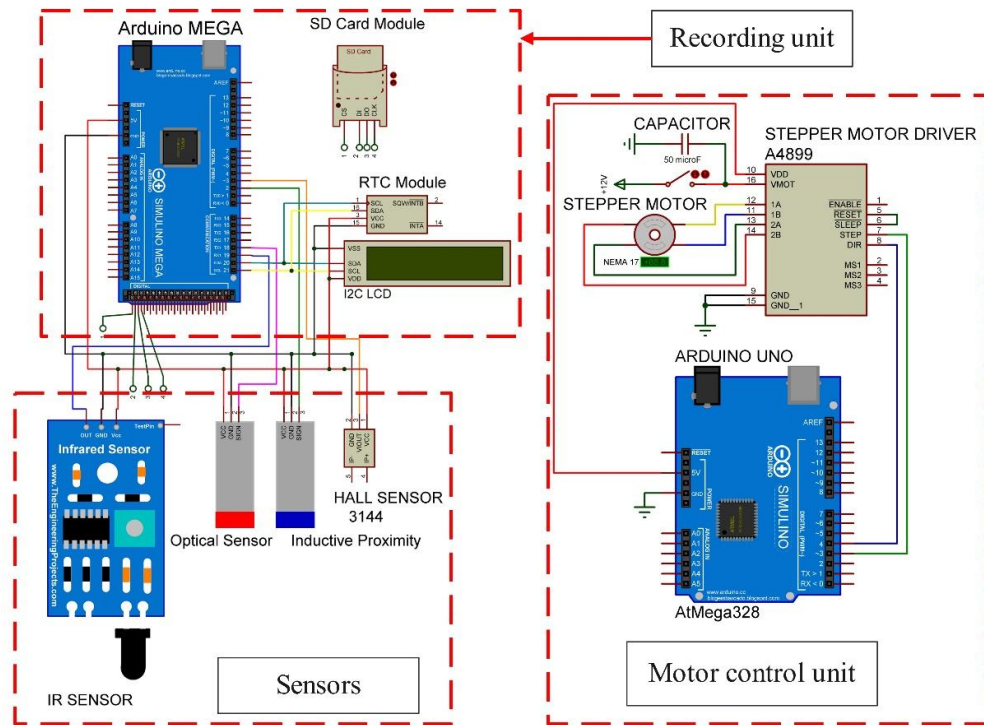

Fig. 2. Circuit diagram of rotational speed measurement unit

Experimental design: All the four sensors were tested according to the experimental plan to select an optimum sensor for rotational speed measurement in lab as well as field conditions (Table 2). The results of the experiment on effect of working environment and distance between sensor and target was analysed using full factorial design in 'SPSS' software. The means of each level were compared using Tukey's (b) method.

Test procedure: The stepper motor was operated using DC power supply and the speed was recorded at an interval of 10 rpm in different working environment and distance between

sensor and target. The speed of the stepper motor was varied with help of controller unit. The data of measured values at varied rotational speeds were recorded by different sensors in SD card with the help of recording unit. The light intensity while performing the experiment in indoor environment was 78 lux whereas, in case outdoor environment it was 59000 lux (Delta Ohm HD 9221 lux meter). The dusty environment in outdoor condition was created using an air blower having flow rate of $3 \text{ m}^3 \cdot \text{min}^{-1}$. The dust concentration during the experiment was recorded as $5 \text{ g} \cdot \text{m}^{-3}$ (Dust meter). Actual rpm of the rotating disc was measured using non-contact tachometer (TM-5000, accuracy $\pm 1 \text{ rpm}$).

Table 2. Plan of work for sensor testing

Independent parameters	Levels	Values
Sensors	4	Inductive proximity sensor Infra-red sensor Hall effect sensor Optical proximity sensor
Working environment	3	Indoor Outdoor without dust Outdoor with dust
Distance between sensor and target	2	2 and 5 mm
Dependent parameters		
Percentage deviation in speed		

Table 3. Details of working environment during performance assessment of sensors

Parameters	Indoor	Outdoor	Outdoor Dusty
Light Intensity, lux	78	59000	59000
Temperature, °C	28	35	35
Relative Humidity, %	70	40	40
Dust concentration, g.m ⁻³	0.04	0.12	5

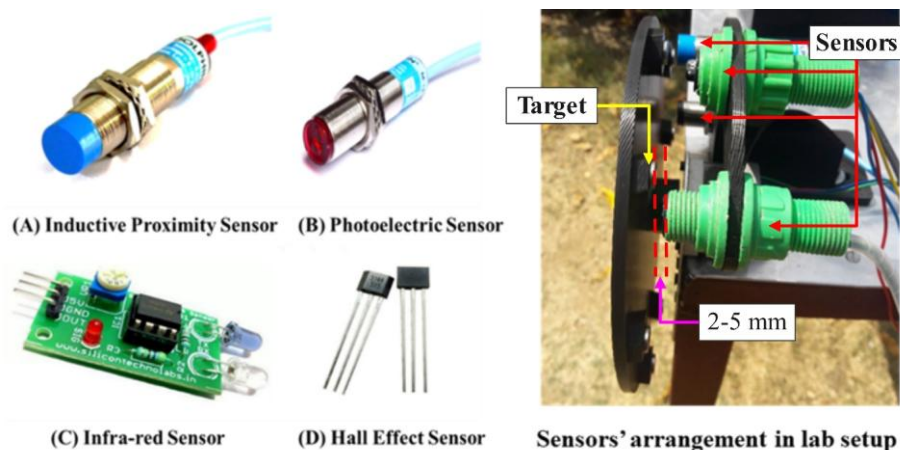

Fig. 3. Different sensors tested and their arrangement in lab setup

3. RESULTS AND DISCUSSION

The accuracy of the sensor in measurement of rotational speed was analyzed in terms of percentage deviation from the actual value. The four sensors were tested in different combination of working environment and distance between sensor and target. The results were analyzed using full factorial design and the comparison of the means for each level was compared using Tukey's (b) method at 5% level of significance. The statistical analysis indicated that the effect of all the three parameters i.e., sensor type, working environment and distance between target and sensor had significant effect on percentage deviation in speed at 1% level of significance. The first order and second order interaction between sensor type, working environment and distance between target and sensor were also significant at 1% level of significance. The Table 4 indicates that the mean value of percentage deviation in speed for all the four sensors were significantly different with each other. However, in case of working environment there was significant difference in mean values of indoor and outdoor dusty condition for hall effect sensor at 2 and 5 mm distance between sensor and target at 5% level of significance. Whereas, there was no significant difference indoor and outdoor condition. The values of percentage

deviation in speed for all the three-working environment in case of inductive proximity sensor was significantly different at 5% level of significance. The percentage deviation in speed was significantly different in indoor and outdoor condition for IR and optical proximity sensor at 5% level of significance. The hall effect sensor had minimum deviation in all working environment at both distances between sensor and target. The maximum deviation was observed in the values of optical proximity and IR sensor and significantly affected by the working environment (Fig. 4). The percentage of deviation in speed for Hall effect, inductive proximity, IR and optical proximity sensors varied from 0.55 to 1.03, 1.20 to 32.29, 21.37 to 100.00 and 35.18 to 99.98 respectively (Table 5). Due to high intensity of light (59000 lux), IR sensor and optical proximity sensor were not responding to the rotational speed because they work on the principle of reflection from the surface. The sunlight interferes with the light emitted by the sensor thus changing the output values. Hall effect sensor had shown minimum deviation from actual value because sensors based on non-optical principle are very less affected by changing environment [18,19]. Sreenivasulu and Raghavendra [14] found similar results for Hall effect sensor that can work in robust conditions for rotational speed measurement.

Table 4. Effect of different working environment and spacing between sensor and target on performance of sensors

Source	F	p value
Corrected Model	2832.414	<0.0001
Intercept	60607.65	<0.0001
Spacing	71.648	<0.0001
Sensors	13065.74	<0.0001
Working conditions	7724.056	<0.0001
Spacing * Sensors	55.374	<0.0001
Spacing * Working conditions	18.911	<0.0001
Sensors * Working conditions	1676.872	<0.0001
Spacing * Sensors * Working conditions	27.231	<0.0001

Table 5. Interaction table

Distance b/w sensor and target	Working condition	Hall Effect Sensor	Inductive Proximity Sensor	IR Sensor	Photoelectric Sensor
2 mm	Indoor	0.55 ^{Aa}	1.20 ^{Ab}	21.37 ^{Ac}	35.18 ^{Ad}
	Outdoor	0.53 ^{ABa}	12.52 ^{Bb}	99.46 ^{BCc}	99.20 ^{BCd}
	Outdoor Dusty	1.03 ^{Ca}	32.29 ^{Cb}	99.96 ^{Cc}	99.98 ^{Cd}
5 mm	Indoor	0.56 ^{Aa}	5.86 ^{Ab}	11.59 ^{Ac}	17.76 ^{Ad}
	Outdoor	0.56 ^{ABa}	16.38 ^{Bb}	99.54 ^{BCc}	88.86 ^{BCd}
	Outdoor Dusty	0.60 ^{Ca}	28.83 ^{Cb}	100.00 ^{Cc}	99.27 ^{Cd}

*Factors with different alphabetic letters are significantly different at 5% level of significance

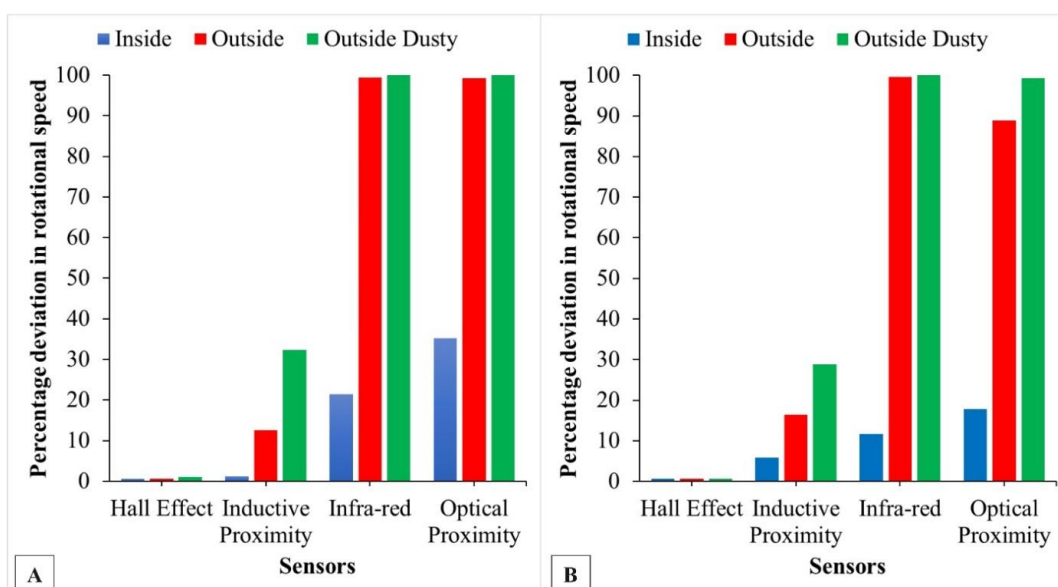

Fig. 4. Effect of working environment on sensor performance at (A) 2 mm and (B) 5 mm distance between sensor and target

4. CONCLUSION

The developed system was adequate to test the sensors in different working environment and spacing between sensor and target. The working environment significantly affected the performance of the sensors. However, the

percentage deviation in speed measurement by Hall effect sensor was minimum (0.55 to 1.03%) compared to the other three sensors. Therefore, Hall effect sensor can accurately measure the rotational speed without being affected by the working environment in lab as well as field.

COMPETING INTERESTS

Authors have declared that no competing interests exist.

REFERENCES

1. Moinfar A, Shahgholi G, Gilandeh YA, Kaveh M, Szymanek M. Investigating the effect of the tractor driving system type on soil compaction using different methods of ANN, ANFIS and step wise regression. *Soil Till Res.* 2022;222:1-10.
2. Raheman H, Jha SK. Wheel Slip Measurement in 2WD tractor. *J Terramech.* 2007;44(1):89-94.
3. Ashok Kumar A, Tewari VK, Gupta C, Pareek CM. A device to measure wheel slip to improve the fuel efficiency of off road vehicles. *J Terramech.* 2017;70:1-11.
4. Pieniążek J, Ryba P. 'Eddy-Current Sensor for a Tachometer.' *prace Instytutu lotnictwa.* 2017;247(2):57-68.
5. Mishra P, Pradhan S, Sethiya S, Chaudhary V. Contact less tachometer with auto cut off. *Int Res J Eng Technol.* 2017;4(4):369-71.
6. Ehikhamenle M, Omijeh BO. Design and development of a smart digital tachometer using At89c52 microcontroller. *Am J Electr Electron Eng.* 2017;5(1):1-9.
7. Hamada H, B. Microcontroller based LADAR system for speed detection. *Int J Appl Inf Syst.* 2014;6(7):33-5.
8. Zhou Y, Dong L, Zhang C, Wang L, Huang Q. Rotational speed measurement based on LC wireless sensors. *Sensors (Basel).* 2021;21(23):8055.
9. Ma ZQ, Zhang R, Kang DL, Yang W. A research of high precision rotational speed measurement system based on infrared Sensor and microcontroller. *Appl Mech Mater.* 2013;278-280:680-3.
10. Negi A. Tachometer using Arduino and hall effect Sensor; 2017. *Engineer Experiences* [cited Mar 7, 2018]. Available:<http://engineerexperiences.com/tachometer-using-arduino.html>
11. Jia R, Rui-chang J-SO, Lin H, Chen J, Hong-lian Lin, and Jin-fu Chen. A real-time differential anti strong interference tachometer based on Arduino. *dtetr International Conference on Applied Mechanics, Electronics and Mechatronics Engineering.* 2016; (ameme).
12. Todorović AS, Jevtić MD. 'Rotational Speed Measurement Using Induction Coil Sensor Inserted in the Magnetic Field of the Rotational Permanent Magnet.' *Facta universitatis-series: Electronics and Energetics.* 2010;23(2):199-206.
13. Chouthai A, Karhu R, Kulkarni S. RPM measurement and calculations using TSOR IR receiver. *Int J Adv Res Electr Electron Instrum Eng.* 2013;2(7):3357-62.
14. Sreenivasulu G, Rao K. Raghavendra. Indian J Sci Technol. Design and Development of Linear Velocity Measurement System using Texas Instruments Hall Effect Sensor DRV5023-Q1 and Microcontroller MSP430G2553. 2016;9(38):1-11.
15. Palacín J, Martínez D. Improving the angular velocity measured with a low-cost magnetic rotary encoder attached to a brushed DC motor by compensating magnet and hall-effect sensor misalignments. *Sensors (Basel).* 2021;21(14):1-12.
16. Fernández MV. Arduino based Data Acquisition System. B.Tech. Project Report; 2016.
17. Aiea VM. Interfacing Catalex micro SD card module with Arduino; 2017 [cited Dec 26, 2018]. Available: <http://www.vishnumaiea.in/projects/hardwa re/interfacing-catalex-micro-sd-card-module>.
18. Osadcuks V, Pecka A, Lojans A, Kakitis A. Experimental research of proximity sensors for application in mobile robotics in greenhouse environment. *Agron Res.* 2014;12(3):955-66.
19. Mahore A, Kushwaha HL, Kumar A, Khura T. A low-cost wheel slip measurement device for agricultural tractors. *Indian J Agri Sci.* 2022;92(3):334-8.

© 2023 Mahore et al.; This is an Open Access article distributed under the terms of the Creative Commons Attribution License (<http://creativecommons.org/licenses/by/4.0>), which permits unrestricted use, distribution, and reproduction in any medium, provided the original work is properly cited.

Peer-review history:

The peer review history for this paper can be accessed here:

<https://www.sdiarticle5.com/review-history/97087>