



## Laboratory Setup for Sensing Root-Induced Changes of Soil Hydraulic Properties in Soil Columns

Peter Scholl<sup>1,2\*</sup>, Reinhard Nolz<sup>1</sup>, Margarita Himmelbauer<sup>1</sup>,  
Gerhard Kammerer<sup>1</sup>, Willibald Loiskandl<sup>1</sup>, Hans-Peter Kaul<sup>2</sup>  
and Gernot Bodner<sup>2</sup>

<sup>1</sup>Institute of Hydraulics and Rural Water Management, University of Natural Resources and Life Sciences, Vienna, Muthgasse 18, 1190 Vienna, Austria.

<sup>2</sup>Department of Crop Sciences, Division of Agronomy, University of Natural Resources and Life Sciences, Vienna, Konrad Lorenz-Straße 24, 3430 Tulln, Austria.

### Authors' contributions

This work was carried out in collaboration between all authors. Author PS drafted and submitted the manuscript. He was responsible for the practical implementation of the project idea, including the establishment, test operation and experimental usage of the whole laboratory setup. Several detailed solutions were developed in cooperation with authors RN, GK and WL. Moreover they gave valuable comments during experimental setup development, sensor validation and the interpretation of derived datasets. Author MH was directly involved in sensors validation processes. Authors GB and HPK developed the initial idea of the study and provided scientific advice throughout the entire term. All co-authors have read the manuscript, gave valuable inputs and comments and agree with the submitted version.

### Article Information

DOI: 10.9734/IJPSS/2015/20604

#### Editor(s):

(1) Ying Ouyang, United States Department of Agricultural Forest Service, USA.

#### Reviewers:

(1) Rajaram pandurang dhok, Savitribai Phule Pune University, Pune, India.

(2) Teresa Lopez-Lara, Autonomous University of Queretaro, Mexico.

(3) Tunira Bhadauria, Kanpur University, India.

Complete Peer review History: <http://sciencedomain.org/review-history/11623>

Original Research Article

Received 31<sup>st</sup> July 2015  
Accepted 14<sup>th</sup> September 2015  
Published 29<sup>th</sup> September 2015

### ABSTRACT

Structural porosity is a dynamic soil property with high spatio-temporal variability affected by many factors. In order to develop a quantitative understanding of root driven changes in soil hydraulic properties adequate measurement setups are required. A modular soil column setup for drainage

\*Corresponding author: E-mail: [peter.scholl@boku.ac.at](mailto:peter.scholl@boku.ac.at);

experiments providing all data for inverse determination of soil hydraulic properties was developed. The aim of this paper is to present the overall setup, and to assess if the influence of an experimental factor (plant roots) can be captured by the system.

The designed setup facilitates simultaneous measurements of soil water content (TDR-sensor), matric potential (tensiometer) and column bottom flux (balance) in 12 soil filled columns. In total 144 soil water sensors ensure a high spatial and temporal resolution (six 10 cm layers per column, time steps  $\geq 5$  min). An initial drainage experiment with 12 unplanted columns was combined with a second (final) drainage run investigating the variants mustard (*Sinapis alba* L.), rye (*Secale cereale* L.) and an unplanted control in four replicates. A specific data acquisition system was developed to operate the devices, and for data synchronization and management. The included semi-automatic trouble-shooting routine sustained long-term experiments. Our analyses showed very low inter-sensor variability for TDR-sensors and tensiometers (0.2 - 0.5% and 1.2 - 4%, respectively). Cumulative outflow data indicated only a minor contribution to variability (6.1%) between columns due to heterogeneity from filling. Therefore, a significant effect of the experimental factor plant root was not overlaid by higher variability due to undesired effects, and could be clearly identified. We concluded that the setup is adequate to identify root induced changes of soil hydraulic properties using designed experiments.

*Keywords: Roots; soil column experiment; TDR-sensor; tensiometer; data acquisition system; soil hydraulic properties.*

## 1. INTRODUCTION

Roots fulfil several key functions for plant growth and environmental sustainability such as water and nutrient uptake, assimilate storage, plant anchorage, soil structure stabilization and biopore formation. Root influences on soil structure are essential drivers of soil hydraulic properties, and consequently overall soil hydrology [1-3]. Soil hydraulic properties are commonly described by hydraulic conductivity and a water retention function. The latter expresses the relation between soil water content (amount of water within a certain volume of soil) and matric potential (energy needed to withdraw water from a certain point in the soil) [4]. Quantifying root-induced changes of soil hydraulic properties is complex due to the various possible influences and their spatio-temporal variability. Major impacts arise from local compaction, microfissuring, hydrophobicity, pore clogging, enhanced microbial activity, biopore formation, and pore stabilization (e.g. Scanlan [5], Głab & Szewczyk [6], Yuge et al. [7], Yunusa & Newton [8], Deborah et al. [9], Mitchell et al. [10], and Whalley et al. [11]). A quantitative understanding of the overall impact of plant roots resulting from these single factors is essential to consider the role of plant driven soil structural dynamics in water transport models. Currently, common soil water models or ecosystem models do not properly consider the manifold interactions between roots, soil and water; e.g. AquaCrop [12-13], Hydrus [14], SWAT [15] and Daisy [16].

In order to develop a quantitative understanding of root-soil interactions, adequate measurement setups are required. In situ measurements in the field allow studying root effects under natural conditions. However, in natural systems soil structure dynamics are affected by multiple biotic and abiotic factors. Therefore, it is difficult to determine the role of a single factor such as plant roots as they might be interfered by other processes [17-18]. In contrast to field measurements laboratory experiments allow studying root effects under controlled conditions.

Laboratory setups to measure temporal changes of soil hydraulic properties under different influences are challenging. Particularly when considering biological factors such as growing plants, numerous system components have to be controlled properly esp. light, water, nutrients, and space to grow [19-20]. Soil texture and bulk density should be similar to natural conditions. Water inflow and outflow (irrigation, evapotranspiration, and lower boundary flux) have to be controlled to simulate a suitable hydraulic environment comparable to natural growing conditions. Furthermore, the size of the experimental pots/soil columns is crucial (cf. Poorter et al. [20-21]): It should allow good root development, with rooting intensity varying predominantly with depth and provide a hydraulic behavior (matric potential distribution) comparable to field conditions.

Besides an adequate model environment in terms of plant growth and soil hydraulic characteristics, the experimental design also has to allow a proper determination of the target variables, i.e. soil hydraulic property dynamics. Soil hydraulic properties of a dynamic system can be determined by inverse modelling [22]. Inverse methods require proper experiments, such as the multistep outflow approach [23]. Multistep outflow experiments are done in common soil sample cylinders (e.g. 250 cm<sup>3</sup>, 6.1 cm height and 7.2 cm inner diameter). This allows an accurate inverse model formulation and a rather simple control of the system, but it is not suitable to study plant effects over time due to the size constraint for plant growth. For larger columns, drainage experiments have been used to determine soil hydraulic properties (e.g. Kosugi and Inoue [24], Ritter et al. [25]). A particular challenge of such experimental setups for inverse modelling of hydraulic properties is an adequate controlling and monitoring of all hydraulic parameters required for inverse optimization (water content, matric potential, outflow) [23]. For example, Scanlan [5] ran soil column experiments (column dimensions: 50 cm high, diameter of 10 cm) based on cumulative outflow data together with water content and matric potential time series just at one depth. He could not detect significant effects of spring wheat roots (*Triticum aestivum* L.) on soil hydraulic properties (sandy substrate). This also indicates another requirement: studying a heterogeneous property, which holds for both soil structure as well as plant roots, requires a proper number of replicates. This again is challenging in terms of experimental setup with multiple sensors and properties (upper and lower boundary fluxes) to be controlled.

According to the soil column size suitable sensors have to be chosen. Not only sensor dimension, but also handling, calibration and reliability are crucial [26-27]. Furthermore, sensors have to provide data resolution being adequate for the purpose of the study. Especially, detection limits and instrument sensitivity have to be taken into consideration [28]. Šimůnek and de Vos [29] emphasised the importance of the input data set quality for the accuracy of any model predictions. Twarakavi et al. [28] stated that inverse modelling based on the nonlinear least-squares method is sensitive to outliers. Continuous monitoring with short measurement intervals and an adequate amount of replications facilitate outlier identification as well as handling of parameter optimization

problems — e.g. convergence of parameter estimation method and non-uniqueness of optimized parameters (e.g. Hopmans et al. [23], Lazarovitch et al. [30]).

In the present study we introduce an experimental setup that was built to determine root effects on soil hydraulic properties. It represents a column setup for drainage experiments with multi-layer sensor equipment to capture heterogeneous root effect with depth. The laboratory setup comprises different controlling and monitoring devices (sensors) as well as a specific software to operate the devices and to synchronize and manage the huge amount of data to be used for subsequent inverse parameter estimation of a hydraulic model.

The main objectives of this paper are (1) to present in detail the established laboratory setup for data acquisition to be used in inverse hydraulic property determination, and (2) to assess if such a replicated multiple component system allows a reliable determination of an experimental factor effect (e.g. root influences) compared to components of residual system variance (sensors, column setup). While results from a specific application for root effects on soil hydraulic properties were presented in Scholl et al. [31], the aim here is to evaluate the technical setup and present general recommendations on setup, sensors and control software for different applications based on soil column experiments.

## 2. MATERIALS AND METHODS

The experimental system consists of soil columns, soil water sensors, several peripheral devices (e.g. balances, irrigation pump, growth lamps), and a control and data acquisition system. Fig.1 gives an overview of the system and all installed components.

The experimental design is comparable to setups used for drainage experiments by e.g. Scanlan [5], Kosugi and Inoue [24], Ritter et al. [25], and Yang et al. [32]. Key elements of our design are (i) a higher number of columns (12) to allow proper replication, (ii) a controlled lower boundary condition with a ceramic pressure plate to increase the soil moisture range over the drainage process compared to a freely draining system, and (iii) sensor equipment in various depths (six layers) to provide information on spatial heterogeneity with depths (which is of

obvious relevance when e.g. considering roots with decreasing density over depth). In comparison to this, Kosugi and Inoue [24] used one column with free drainage. Ritter et al. [25] and Yang et al. [32] used only one column, whereas the setup established by Scanlan [5] featured several replicates but only one sensor per column. Our cylindrical soil columns were made of 4 mm thick plexiglass. Each cylinder was 60 cm high and had a diameter of 15 cm. The transparent soil columns were wrapped with a black textile to keep them dark and thus minimize algae growth. Due to the cylindrical shape of the column the sidewall was not completely plane (circular arc). Therefore, we prepared spots for sensor installation by countersinking a hole in the wall and fitting a plane disk of 4 mm thickness on it.

For controlled drainage experiments a micro drip irrigation system was installed at the top of each soil column ensuring water supply during plant growth as well as a controlled upper boundary flux condition at the beginning of a drainage experiment. It was connected to a 10 L water tank. All pipes featured the same length regardless of the distance between soil column

and water tank. The corresponding 12-channel-dispensing pump (ISMATEC, IPC) was controlled by a microprocessor. Irrigation system accuracy was tested per column by simple flow measurements at different preset flow rates ( $1\text{--}100\text{ mm m}^{-2}\text{ h}^{-1}$ ).

A porous ceramic suction plate (air entry point =  $-800\text{ hPa}$ ) was placed at the bottom of each soil column as indicated in Fig.1. The lower boundary condition was controlled by a vacuum pump (UMS, VS Vacuum System) connected to the ceramic plate. The vacuum pump provided a relative pressure of 0 to  $-850\text{ hPa}$  with an accuracy of  $\pm 0.5\text{ hPa}$ . A pipe leading from the ceramic plate to a glass bottle ( $V = 2\text{ L}$ ) allowed collecting the outflow of each column separately. Each bottle was placed on a digital balance (Kern, FCB 6K0.5; precision  $\pm 0.5\text{ g}$ ), which recorded bottom outflow continuously and in temporal synchronization with soil water content and matric potential measurements. Pipes from the column outlet to the collecting bottles were mounted in a way to avoid any disturbance of the balances. Leak-tightness and pressure stability of the whole vacuum system were checked repeatedly using an additional pressure gauge.

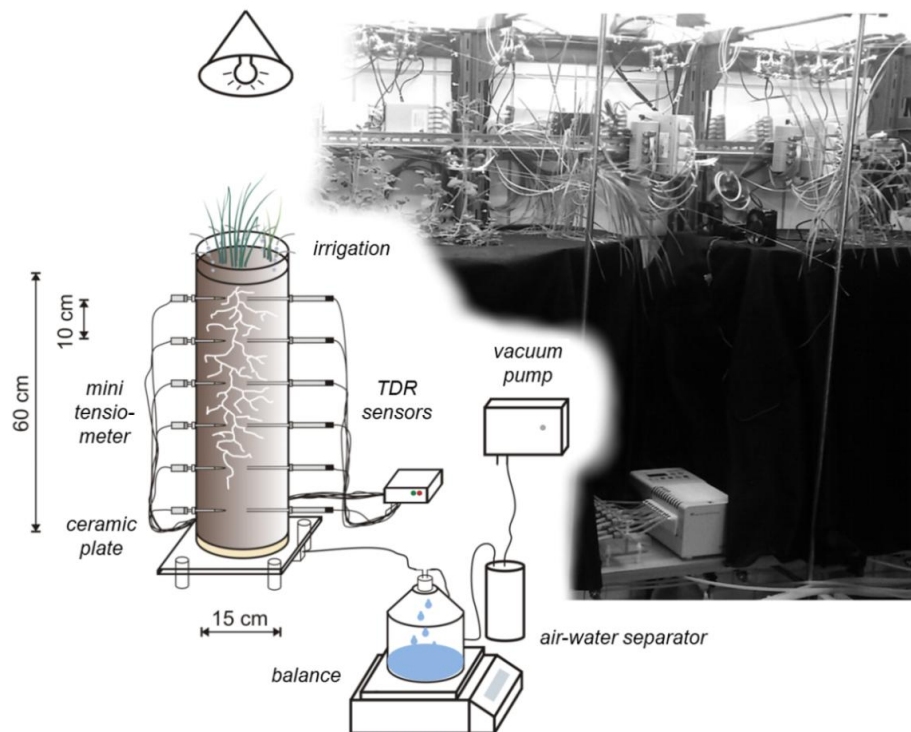

**Fig. 1. Overview of the experimental setup**

As a peripheral hardware component of the experimental design, growth lamps (8 x Sylvania GroLux F 58 W, 4 x Narva LT 58 W) covered by a reflector were mounted one meter above the soil columns for ideal light conditions. They were controlled by a simple analogue timer, adjustable in 15 min steps ( $24 \text{ h d}^{-1}$ ).

## 2.1 Column Filling

A careful soil column preparation is crucial to ensure the initial homogeneity of the system. The columns were filled with soil from an experimental site where parallel field research was performed [18]. The soil type was a calcareous chernozem with a silt loam texture ( $0.19 \text{ kg kg}^{-1}$  sand,  $0.56 \text{ kg kg}^{-1}$  silt,  $0.24 \text{ kg kg}^{-1}$  clay). Soil organic carbon content ( $0.025 \text{ kg kg}^{-1}$ ) was calculated by subtracting inorganic carbon content (measurement device: SoliTIC; Elementar, Hanau, Germany) from total carbon amount, measured by a varioMAX CN (Elementar, Hanau, Germany). Soil material was air dried and sieved to a particle size  $<2 \text{ mm}$ . Using an initially homogeneous substrate is supposed to allow better analysis of the effect of experimental factors (e.g. plant roots) via the distinct spatio-temporal heterogenization of soil properties. Sterilization of the substrate by steam autoclaving was done to simplify the interpretation of root induced changes excluding microbial effects. The columns were filled carefully to avoid any layering or displacement of fine soil particles with a stepwise compaction of 5 cm thick layers to a target bulk density of  $1.3 \text{ g cm}^{-3}$ . Boundary compaction was prevented by loosening the contact area of each layer with a screwdriver. Finally, a 2 cm thick layer of fine gravel was added on top of the columns aiming to reduce evaporation as well as to prevent any potential changes of soil surface characteristics during irrigation. To reduce soil settlement over time, each column was saturated and drained at least three times before starting the experiments. Saturation was carefully performed from the

bottom by gradually raising up a water reservoir in order to prevent shifting of small soil particles.

## 2.2 Installed Sensors

In order to consider vertically layered soil hydraulic properties at every 10 cm-depth from 5 to 55 cm, one TDR-sensor (LP/ms EasyTest, Poland) and one tensiometer (LP/p EasyTest, Poland) were paired together. Both sensor systems are well-established techniques [4], but the choice of devices suitable for laboratory application is limited: The sensors should feature a small size and support data bus technology which enables handling of a comprehensive multi-sensor setup. The EasyTest sensors were selected following reports of favourable performance in laboratory use by Loiskandl et al. [26] and Himmelbauer et al. [27].

### 2.2.1 TDR-sensors

Time-domain reflectometry (TDR) is a well-established technique for measuring volumetric soil water content ( $\theta_v$ ) [33]. A voltage pulse or signal is reflected from the ends of two parallel metal rods installed in a dielectric medium and returns to a receiver. The sensor analyses the time between sending and receiving the signal expressed as real permittivity ( $\epsilon_r$ ). According to the nature of the medium (soil with water) the measured value of  $\epsilon_r$  varies. In a second step  $\epsilon_r$  is recalculated by defined equations to  $\theta_v$  [4].

The stainless steel rods of the used mini-TDR sensor type LP/ms are 53 mm long and 5 mm apart. According to the manufacturer the region of influence is a cylinder with a diameter of 5 mm and a height of 60 mm around the sensor rods. Further information about the EasyTest LP/ms sensors is given by Malicki et al. [34]. Originally, these small TDR-probes have been developed for analysing unsaturated soil water flow characteristics in undisturbed standard sampling cylinders [34]. The manufacturer equations for converting  $\epsilon_r$  to  $\theta_v$  are:

$$\theta_v = 0 \quad \text{if} \quad \sqrt{\epsilon_r} < 1.48733 \quad (1)$$

$$\theta_v = 0.106387 \times \sqrt{\epsilon_r} - 0.158247 \quad \text{if} \quad \sqrt{\epsilon_r} < 6.0 \quad (2)$$

$$\theta_v = 1 - (1 - 0.106387 \times 6 - 0.158247) \times (9 - \sqrt{\epsilon_r})/3 \quad \text{if} \quad \sqrt{\epsilon_r} \geq 6.0 \quad (3)$$

According to organic matter content, texture, electrical conductivity and temperature of the used substrate, electromagnetic TDR-probe output might differ from given  $\theta_v$ . Hence, LP/ms-sensor standard converting equation (eq. 2) was validated for our soil conditions in the range of 0.10–0.45  $\text{cm}^3 \text{cm}^{-3}$  by comparison of measured values to gravimetrically determined soil water contents. For this purpose four glass beakers were filled with 250 g substrate (bulk density = 1.3  $\text{g cm}^{-3}$ ). Soil water content was adjusted by adding a controlled amount of water to achieve a certain saturation level. The compacted and wetted soil was covered by a top disk which facilitated the proper vertical installation of one TDR-sensor per glass beaker (cf. Fig. 5a). In order to ensure optimum soil-sensor contact without air gaps we inserted the TDR sensors by using the plastic guide delivered with each sensor. Afterwards the glass beakers were made air tight by covering with para-film and left three days to ensure uniform soil water content within the whole soil volume. Thereafter the TDR-sensors were inserted for  $\theta_v$  measurement. Particularly at high saturation handling has to be done with care to avoid any changes in structure and bulk density via pressure on the top disk. Measurements were done in four replicates.

### **2.2.2 Tensiometers**

Tensiometers are devices to directly measure soil matric potential ( $\psi$ ). A tensiometer consists of two air tight connected and water filled parts: (i) a porous ceramic cup at the end of a shaft and (ii) an electric pressure transducer or manometer. When the tensiometer is installed in the soil, pores of the ceramic cup allow a hydraulic contact of soil water and tensiometer water which tends to equilibrate. Soil matric potential performs a suction effect, which lead to a negative pressure head at the transducer [4].

A complete technical description of the used EasyTest LP/p tensiometers was published by Plagge et al. [35]. The pressure diaphragm of the LP/p sensor consists of a 15 mm long ceramic cup (diameter: 3 mm) fixed on a metal shaft.

For preparation the 72 tensiometers were carefully filled with water. Air inside the ceramic tips was removed under vacuum and the tips were simultaneously filled with demineralised, deaerated water. The inside of the pressure transducer was filled by the help of a winged infusion set (smallest available size). This

procedure was repeated for each experimental run.

The LP/p-pressure transducer readings were validated by the use of an additional setup. Both air-water separators (one per six soil columns, displayed in Fig. 1) of the installed vacuum system were equipped with an exchangeable lid (Fig. 2). In this way it was possible to fix another base lid with accurately-fitting slots supporting up to nine LP/p sensors (cf. Fig. 6). The plexiglass cylinder was then filled with water up to the metal shafts of the installed tensiometers with the ceramic cups under water and leaving a small air-filled gap in the container. Finally the vacuum pump with an additional pressure gauge was connected. For validation pressure head was reduced stepwise in the range of 0 to –50 kPa.

Discharge measurements of the irrigation system showed a high precision (range of 1-99  $\text{mm h}^{-1}$ ) with negligible differences among columns. Also the vacuum system worked precisely and very reliably. In spite of the large system volume (~26 L) preset pressure heads were adjusted quickly. Special attention had to be paid on saturation of the ceramic plates during long-term measurements. Typically they dry out after a couple of weeks (depending on their porosity). Therefore, it is necessary to saturate them before each measurement series and check the tightness of the vacuum system regularly. Saturation of the ceramic suction plate was carefully done from the bottom of each column (Fig. 1) by connecting a small water reservoir (250  $\text{cm}^3$ ) to the column bottom flux outlet. Balance precision only slightly differed under changing air temperature conditions. Still during measurement series over longer time regular cleaning of balances from dust and dirt is required to avoid biased readings.

### **2.3 Control and Data Acquisition Software**

A key challenge for running the laboratory experiment was synchronisation of numerous different measuring devices, using various PC-interfaces. The control of balances (Kern, FCB 6K0.5), multiplexer (LOM, Easy Test) with connected TDR-sensors and tensiometers, vacuum system (UMS, VS Vacuum System) as well as the irrigation supplied by a high precision dispensing pump (ISMATEC, IPC) had to be merged in one control software. For this purpose a control software “Bokerlom” was developed which allowed an easy setup and synchronized

the dataflow of the four data sources (balances, sensors, vacuum system, irrigation). Measurement values were recorded and assigned to distinct data files. The software was written in the programming language C# and is based on MS.Net Framework 4.0 since we used operating systems MS Windows XP and Windows 7, respectively. The TDR and tensiometer reading software provided by EasyTest [36] was just used at the beginning to create an input file including all digital sensor addresses.

line driver. This technical need however had no influence on the transmitted data-information.

Experiments over longer time spans (e.g. several months of plant growth) have a high requirement of failure safety to avoid data gaps. Therefore, a proper trouble shooting procedure was developed: Actions could be performed manually (by the user) or semi-automatically. Thus, in addition to the setup control function "Bokerlom" also included a validation procedure for all incoming information as a basis for trouble shooting. A comprehensive LOG-Display provides the user with the possibility of a fast assessment of the current system state. If there are any readings out of the normal range, the software will automatically start predefined trouble shooting actions (cf. section 3.2) according to the identified problem origin.

Fig. 3 gives an overview of the data flow managed by our software. Due to unstable RS 232-connections of the balances, their output signals had to be amplified from 3 V to 10 V. Therefore, we developed a 4-channel RS 232

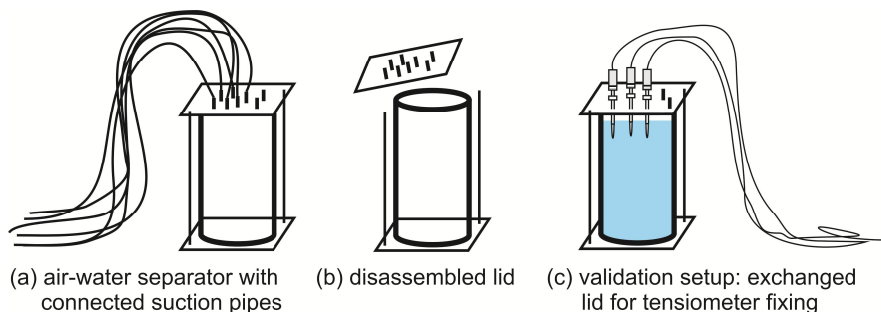

Fig. 2. Sketch of the tensiometer validation setup

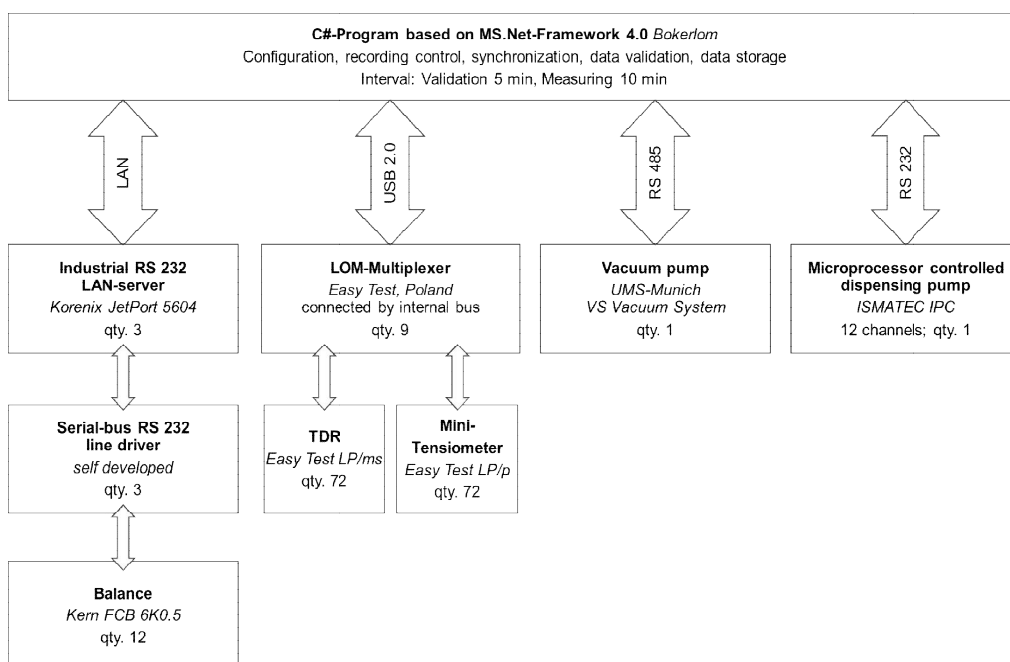

Fig. 3. Overview of the data flow controlled by "Bokerlom"



## 2.4 Statistical Evaluation of Experimental Factor Identification

There are various sources of influence on the measured data time series during a drainage experiment that is used for inverse determination of soil hydraulic properties. A drainage experiment [31] comprises an initial wetting/saturation of the soil columns until a constant outflow is obtained (steady flux initial condition). Thereafter irrigation is stopped and the columns are drained under a defined lower boundary pressure head (-50 kPa). Inverse optimization is based on the time series of water content, pressure head and cumulative outflow. Comparison is made between the initial hydraulic properties before any plant root influence and the final hydraulic properties modified by plant roots. Details can be found in Scholl et al. [31]. A flow chart of an experimental run within the system is given in Fig. 4.

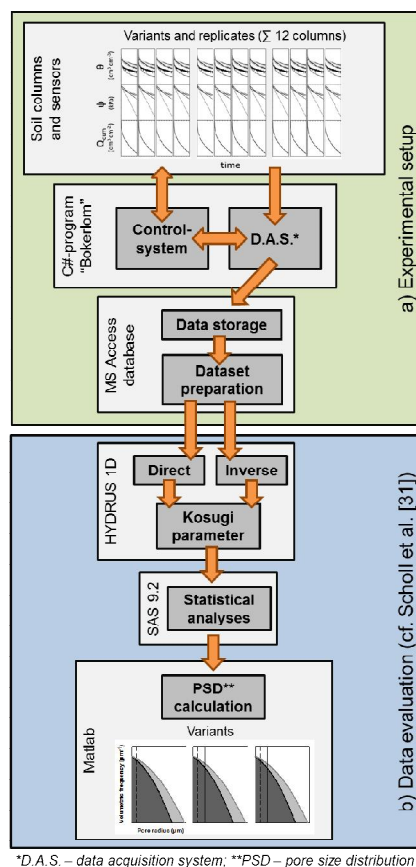

Fig. 4. Flowchart of the laboratory experiment

Influence on the measured time series include (i) undesired effects from sensor variance, non-homogeneous filling of the columns and

heterogeneous initial conditions in the drainage experiment, (ii) natural spatial differences in the system state over depth (bulk density) as well as changes over time not related to any designed experimental factor (e.g. soil settlement), and (iii) the influence of the designed experimental factor (e.g. rooted vs. unrooted). The overall experimental setup (sensor validation, column filling, initial settling, and irrigation control) has to ensure that the significance of any designed experimental factor (e.g. root influences) can be clearly identified and is not overlaid by higher variability due to undesired effects.

Results from sensor validation are given in section 3.1 providing an estimate of the sensor induced variability. Information on the column heterogeneity resulting from the filling procedure is obtained by analysing the contribution of the error variance compared to the other experimental factors with cumulative outflow data. Cumulative outflow is used as a comprehensive measurement parameter integrating over the whole column depth. Furthermore we analyse the variability of total porosity in the columns at the beginning of the experiment. Total porosity data are obtained from saturated water content measurement at the third saturation-drainage cycle before imposing the different treatments (here: two plant species with distinct root systems vs. an unplanted treatment) on the columns.

Finally we use TDR and tensiometer readings during the initial and final drainage experiments at different saturation levels to obtain the significance of each factor that influences the soil water sensor readings. This again tests the significance of the designed experimental factor (i.e. rooted vs. unrooted soil columns) as well as the expected effects within the experiment (column depth, time after starting of the drainage experiment) against the error variance which includes all undesired effects inducing inter-column variability (sensor variability, heterogeneous filling, and heterogeneous initial conditions).

## 3. RESULTS AND DISCUSSION

### 3.1 Soil Water Sensors

#### 3.1.1 TDR-sensors

Results of LP/ms sensor output validation (Fig. 5a) are presented in Fig. 5b. Table 1 gives selected statistical parameters (mean value  $\bar{x}$ ;



standard deviation  $\sigma$ ; coefficient of variation CV; standard error SE) for the sensor variability of TDR outputs at the respective preset gravimetric water content range between low and high water saturation.

Obtained water content readings were within the accuracy of  $\pm 2$  vol% ( $n = 16$ ) as specified by EasyTest for the LP/ms-sensor (Tab. 1), except for  $\theta = 16$  vol% (-2.3 vol%). The variability among sensors was in the range of 0.2 to 0.5%. Thus inter-sensor variability can be expected to only marginally affect treatment comparison with a replicated column experiment. For comparison of sensor accuracy of TDR to gravimetric reference measurements Evett et al. [37]

reported a precision of 2 vol% ( $P = 95\%$ ) for a single measured value via TDR-sensor. Therefore, we considered the accuracy of our system as sufficient also in absolute terms and used the manufacturer equations for converting  $\epsilon_r$  to  $\theta_v$ . Measured  $\theta_v$ -values were always larger than  $20.0 \text{ cm}^3 \text{ cm}^{-3}$ , hence equation 2 ( $\sqrt{\epsilon_r} < 6.0$ ) was relevant for our LP/ms-application range.

### 3.1.2 Tensiometers

Fig. 6b and Table 2 give the results of the validation experiment of the pressure transducers readings of the LP/p tensiometers.

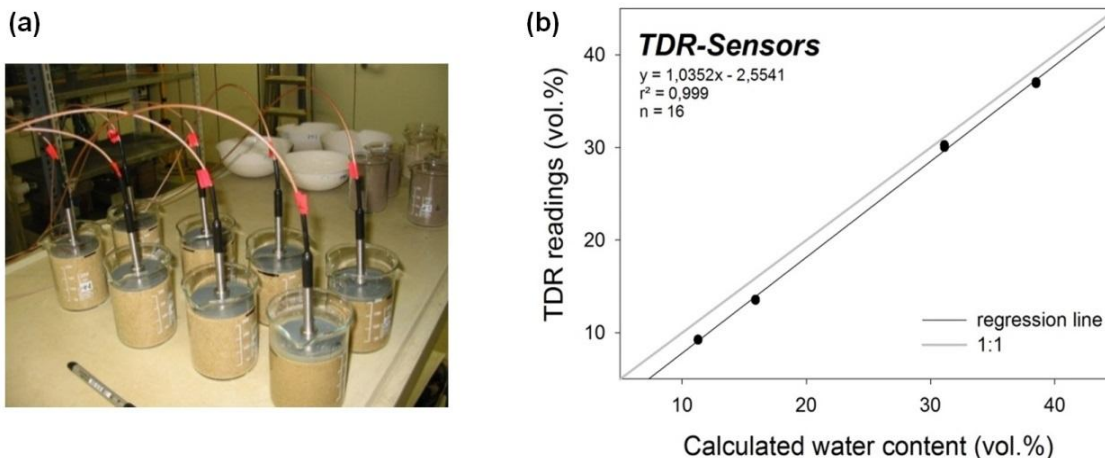

Fig. 5. (a) Validation setup of the TDR-sensors, easy test LP/ms. (b) results of validation procedure, easy test LP/ms

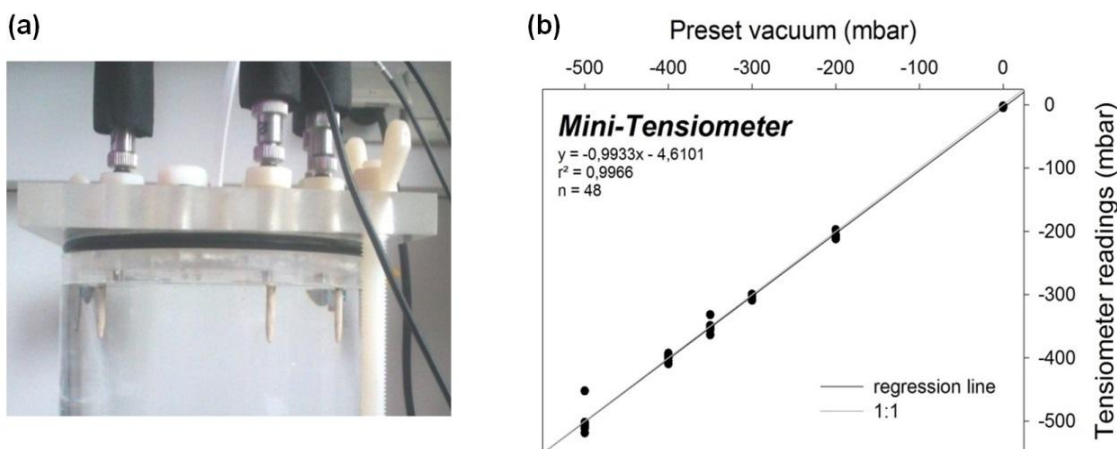

Fig. 6. (a) Validation setup of the tensiometers, easy test LP/p. (b) results of validation procedure, Easy Test LP/p

**Table 1. TDR readings and statistical values during LP/ms validation procedure**

$\theta$ (vol%)	TDR readings (easy test LP/ms)			
	$\bar{x}$ (vol%)	$\sigma$	CV (%)	SE
11.29	9.28	0.05	0.539	0.025
15.91	13.58	0.05	0.368	0.025
31.13	30.18	0.13	0.417	0.063
38.51	37.00	0.08	0.221	0.041

**Table 2. Tensiometer readings and statistical values during LP/p validation procedure**

$\psi$ (mbar)	Tensiometer readings (easy test LP/p)			
	$\bar{x}$ (mbar)	$\sigma$	CV (%)	SE
0	-3.03	0.86	-28.369	0.303
-200	-206.26	4.12	-2.000	1.458
-300	-303.15	3.55	-1.170	1.254
-350	-352.04	9.22	-2.619	3.260
-400	-400.14	5.16	-1.289	1.824
-500	-501.34	20.43	-4.076	7.224

Logged LP/p-values were similar to the preset pressure heads. The tensiometers had (excluding one outlier) a mean relative error of +1% ( $n = 47$ , max.  $\pm 6\%$ ). Thus, the absolute readings of tensiometers do not need any further conversion. The inter-sensor variability was between 1.2% and 4% except for the readings at full saturation (0 mbar). This indicates that the experiment is not biased by tensiometer variability.

In the course of the long-term experiment however some weakness in the LP/p sensors was detected. First the cup was not very resistant against small shearing forces due to shrinking and swelling processes of the soil. Especially the pass of ceramic cup to metal shaft was prone to break (Fig. 7). Furthermore we observed that some tensiometers tended to fail at lower pressure heads. Still the metal shaft did not allow checking if air entry might have interrupted hydraulic continuity. Hence, we chose an alternative tensiometer-tip (ceramic cups of the T5-tensiometer, UMS Munich) that was supposed to work robustly under variable soil and saturation conditions. This cup was connected to a slightly flexible plastic tube (Fig. 7). The two tensiometer types used different threads (T5 owns a fine thread, LP/p a coarse thread). Therefore, a short aluminium adapter was designed for connecting a UMS T5 ceramic tip with the pressure transducer of EasyTest. For functional reliability and measurement accuracy of the tensiometer, transition points (shaft/adaptor as well as adaptor/pressure transducer) were equipped with an o-ring and a custom-fitted silicon gasket. EasyTest LP/p-

installation guide had to be widened (diameter = 5.5 mm) for the UMS T5 tensiometer tip.

In order to ensure that measurement is not interrupted by premature air entry, the first datasets after tensiometer installation and start of the drainage experiment were checked thoroughly. By this, problems could be discovered and solved immediately. Both the original LP/p-sensor as well as the adapted sensors with a T5-cup dried out within 10–15 days. Any insufficient sealing of the main o-ring ((a) in Fig. 7) between pressure transducer and tensiometer shaft can be easily detected during this drying process. Undamaged and still flexible o-rings for sensor assembling are a key to avoid air-entry and requires o-ring replacement before each measurement run as a precautionary measure.

### 3.2 Control and Data Acquisition System

The self-programmed “Bokerlom” control and data acquisition system was used for data collection at 10 minute intervals. Data were exported into a database (MS Access) for final evaluation. It matched sensor raw data (arranged according to sensor address) to the corresponding replicate of each variant (arranged according to sensor type and position). An implemented graphical output allowed a comfortable visual inspection of the recorded data series. A secure data backup of “Bokerlom” was established on a server; regularly once per hour data were synchronized via an independent background process.

Owing to the complex synchronization of different devices various failures may occur. Therefore, the automatic trouble shooting procedures in the “Bokerlom” software (cf. section 2.3) revealed to be highly important. These procedures were based on experiences gained during setup testing. Most problems caused by measurement errors and following erroneous data could be minimized. Table 3 gives a detailed overview on the main setup errors and our trouble shooting recommendations; examples are shown in Table 4 and Fig. 8. LP/ms sensor errors could be generally rectified by a restart of the multiplexers. Likewise LP/p sensor reading failures, except any problems occurred due to damaged transducers, were solved by multiplexer

restarting. Crashed multiplexers could be reactivated by a restart of the devices. Balance reading errors mainly occurred due to an unsettled weighing plate (e.g. high bottom flux at reading time). “Bokerlom” retried to get a stable balance reading for up to five times. In most cases this was long enough to achieve one accurate value.

Additionally to automatic trouble shooting, in most cases “Bokerlom” provided sufficient information about the actual error type in a LOG-Display. For later data handling such a LOG-file that contains all settings and error messages is of high importance.

**Table 3. Lab setup error description and trouble shooting**

<b>Error description</b>	<b>Bokerlom message</b>	<b>Error rate<sup>1</sup></b>	<b>Trouble shooting</b>
<b>LP/ms:</b> reading error cf. Fig. 8 (a)	x	***	<i>What:</i> Restart of the multiplexers: remove devices from the power supply and reconnect them after 10 seconds. <i>When:</i> After finished sensor reading <i>Conducted by:</i> Bokerlom
<b>LP/ms:</b> sensor could not be found	x	*	<i>What:</i> Check the last values of the TDR-sensors. Value "99999.9" detects the lost sensor. Note sensor address and check the cable connection at the corresponding multiplexer. <i>When:</i> As required <i>Conducted by:</i> Bokerlom and user
<b>LP/p:</b> reading error cf. Fig. 8 (b)	x	***	<i>What:</i> Restart of the multiplexers: remove devices from the power supply and reconnect them after 10 seconds. <i>When:</i> After finished sensor reading <i>Conducted by:</i> Bokerlom
<b>LP/p:</b> sensor could not be found	x	*	<i>What:</i> Check the last values of the tensiometers. Value "99999.9" detects the lost sensor. Note sensor address and check the cable connection at the corresponding multiplexer. <i>When:</i> As required <i>Conducted by:</i> Bokerlom and user
<b>LP/p:</b> value increases fast and unexpected during drainage		*	<i>What:</i> Check the corresponding tensiometer about any air entry, high probability. <i>When:</i> As required <i>Conducted by:</i> Bokerlom and user
<b>LP/p:</b> slower reactions in relation to other sensors at the same variant and column layer		*	<i>What:</i> Check the corresponding tensiometer about any air entry, high probability. <i>When:</i> As required <i>Conducted by:</i> Bokerlom and user

<b>Error description</b>	<b>Bokerlom message</b>	<b>Error rate<sup>1</sup></b>	<b>Trouble shooting</b>
<b>Multiplexer:</b> device could not be found	x	*	<i>What:</i> Values "99999.9" detect the lost device. Restart of the multiplexers: remove devices from the power supply and reconnect them after 10 seconds. <i>When:</i> After finished sensor reading <i>Conducted by:</i> Bokerlom
<b>Balance:</b> unsettled weighing plate due to high bottom flux at reading time	x	***/* (start/run time)	<i>What:</i> Retry accurate weighing for max. 5 times. If there is a successfully retry, the measured value gets noted. Otherwise an error is recorded. <i>When:</i> As required <i>Conducted by:</i> Bokerlom
<b>Balance:</b> reading error-value "-99999.9" <i>cf.</i> Tab. 4 (c)	x	**	<i>What:</i> Restart of the LAN-servers: remove servers from the power supply and reconnect them after 10 seconds. <i>When:</i> After finished sensor reading <i>Conducted by:</i> Bokerlom
<b>LAN-server:</b> device could not be found <i>cf.</i> Tab. 4 (b)	x	*	<i>What:</i> Balance values "-99999.9" detect the lost device. Restart of the LAN-servers: remove servers from the power supply and reconnect them after 10 seconds. <i>When:</i> After finished sensor reading <i>Conducted by:</i> Bokerlom
<b>Vacuum pump:</b> pressure loss	x	*	Software induces the pump to hold the pressure according the set threshold. The max. possible actual pressure gets hold. Check the whole vacuum system for any errors. <i>When:</i> As required <i>Conducted by:</i> Bokerlom and user
<b>Vacuum pump:</b> pressure low	x	*	<i>What:</i> Check the whole vacuum system for any errors. <i>When:</i> As required <i>Conducted by:</i> User
<b>Vacuum pump:</b> control LED shines red		*	<i>What:</i> Check the whole vacuum system for any errors and restart the vacuum pump manually. If problems still occur, connect the pump to the USB-adaptor and read out the system error code. Follow manufacturer's trouble shooting instructions. <i>When:</i> As required <i>Conducted by:</i> User
<b>Irrigation pump:</b> low water reservoir			<i>What:</i> NO automatic error message through "Bokerlom"! Ensure enough water in the storage container. <i>When:</i> As required <i>Conducted by:</i> User

*Legend:*

\* ≤ 1error  
\*\* 2-3  
\*\*\* > 3

<sup>1</sup>... frequency during a typical drainage experiment  
(duration: two weeks)

**Table 4. Examples for reading errors (value: -99999.9) of the balances; (a) power blackout, (b) failure of LAN-server 2, (c) reading error of balance 10**

	Time (hh:mm:ss)	LAN-server 1				LAN-server 2				LAN-server 3			
		Bal. 1	Bal. 2	Bal. 3	Bal. 4	Bal. 5	Bal. 6	Bal. 7	Bal. 8	Bal. 9	Bal. 10	Bal. 11	Bal. 12
(a)	07:42:38	2	-2	-6.5	4.5	3	2	-1.5	-1.5	1	2	6.5	0
	<b>07:45:45</b>	<b>-99999.9</b>	<b>-99999.9</b>	<b>-99999.9</b>	<b>-99999.9</b>	<b>-99999.9</b>	<b>-99999.9</b>	<b>-99999.9</b>	<b>-99999.9</b>	<b>-99999.9</b>	<b>-99999.9</b>	<b>-99999.9</b>	<b>-99999.9</b>
	<b>17:40:33</b>	<b>-99999.9</b>	<b>-99999.9</b>	<b>-99999.9</b>	<b>-99999.9</b>	<b>-99999.9</b>	<b>-99999.9</b>	<b>-99999.9</b>	<b>-99999.9</b>	<b>-99999.9</b>	<b>-99999.9</b>	<b>-99999.9</b>	<b>-99999.9</b>
(b)	18:01:46	-3.5	12	-4.5	5.5	2.5	4.5	-3	-5	4.5	9.5	17	-1.5
	14:20:00	250	238	230.5	260	247	268	245.5	302.5	269.5	269.5	281.5	262.5
	14:30:00	250	238	231	260.5	<b>-99999.9</b>	<b>-99999.9</b>	<b>-99999.9</b>	<b>-99999.9</b>	270.5	270.5	283	263
(c)	14:40:00	250.5	238.5	232	261	248	269.5	246.5	303.5	270.5	270.5	283.5	263.5
	16:50:00	1232	1276	1438	1387	1338.5	1390	1356.5	1244.5	1284.5	1217.5	1335	1183.5
	17:00:00	1232.5	1276	1438.5	1387	1339	1390.5	1357	1245	1284.5	<b>-99999.9</b>	1336	1183.5
	17:10:00	1232.5	1276.5	1439.5	1386.5	1339	1391	1358	1245.5	1285	1219	1336.5	1184

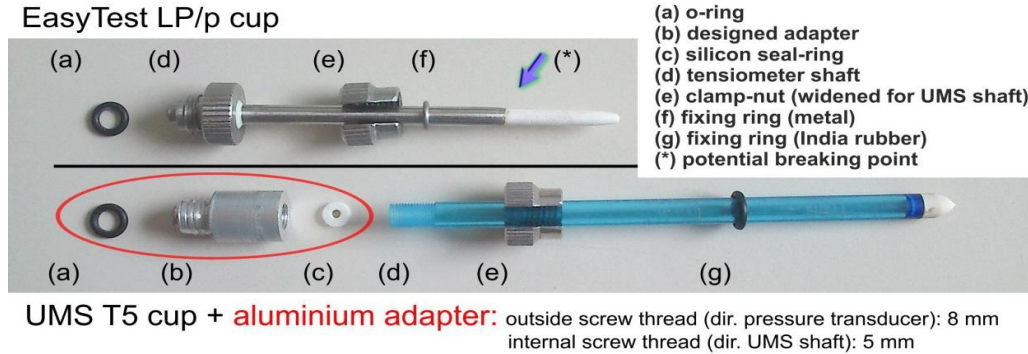

Fig. 7. Original EasyTest LP/p-tensiometer tip vs. adapted UMS T5-tip for the use with the EasyTest pressure transducer

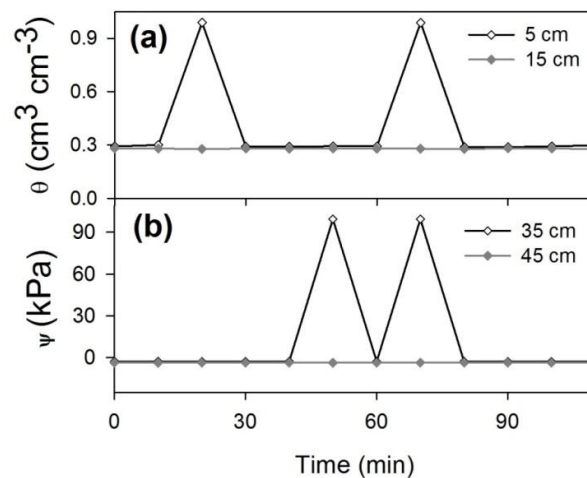

Fig. 8. Examples for reading errors of (a) LP/ms and (b) LP/p and automatic Bokerlom trouble shooting procedure

### 3.3 Experimental Factor Evaluation

As described above, preliminary sensor tests ensured that sensor readings provide reliable absolute measurement data and inter-sensor variability will not bias any designed experiment. In spite of careful compaction and user experience in column filling with the sieved soil substrate, heterogeneous filling could constitute an undesired source of variance overlaying the effect of an experimental factor. Table 5 shows the contribution to total variance from fixed factors vs. residual variance obtained from a general linear model (GLM) analysis of variance. Fixed main factors are treatment (unplanted vs. two different plant species) as well as time (initial experiment before planting vs. final experiment

after three months of plant growth in the planted treatments). Residual error represents the inter-column variance.

It is evident that there was a significant influence of time between initial and final experiment on cumulative outflow. This clearly indicates that in spite of an initial soil settlement from several wetting-drying cycles, there is continued soil settlement during longer experimental runs. This is in agreement with findings from Rühle et al. [38]. Inter-column variability contributed 6.1 % to overall variance when using cumulative outflow as an indicator for overall column heterogeneity. Although the treatment effect only had a minor contribution to variance, its influence was still significant.

Fig. 9 shows total porosity of the columns determined by saturating the columns with a rising water table before (initial) and after (final) imposing distinct planting treatments. The respective contribution to variance is given in Table 5.

**Table 5. Main effects sum of squares (SSQ), contribution to variance and p-value**

	SSQ	Contribution (%)	P > F
Treatment	1.33	2.9	0.0323
Experiment	33.53	72.4	< 0.0001
Error	2.86	6.1	

Here we used a mixed model for analysing the significance of treatment effects to properly consider the repeated depths effect [39]. Among main factors only the temporal change between the initial and final state of the columns was

significant ( $p = 0.0250$ ), while both treatment ( $p = 0.1616$ ) and depths ( $p = 0.6172$ ) were not significant. As suggested by Fig. 9, there was a significant interaction between depth and time ( $p < 0.001$ ); i.e. soil settlement over time resulted in an increasing compaction with depth.

Finally we compared the significance of main effects for TDR and tensiometer sensor readings during the initial and final drainage experiments. Comparison was done at five stages ( $T = 0, 1000, 2500, 4000,$  and  $6250$  min) of the drainage process to cover the whole range from near saturation to the lowest moisture obtained when draining for 104 h and 10 min (cf. Fig. 10). Significance ( $p$ -values) of the main effects of planting treatment, depth and time during the drainage process as well as their interactions are given in Table 6 for the initial and final experiments.

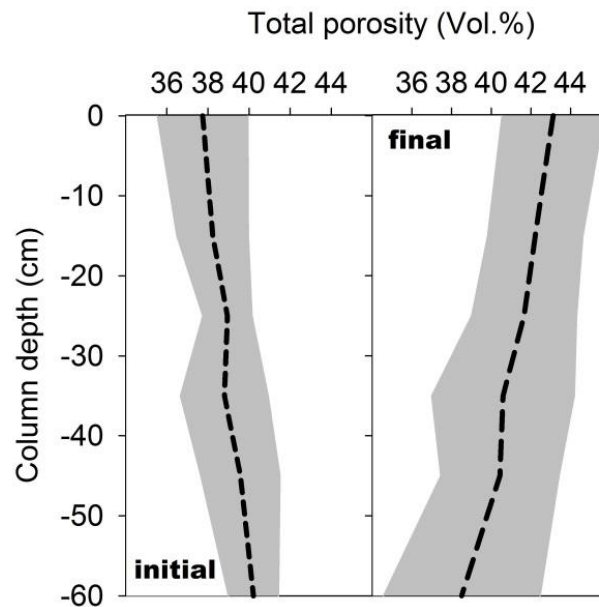

**Fig. 9. Total porosity of the soil before planting and after three months**

**Table 6. P-values of the main effects during the drainage process**

	TDR		Tensiometer	
	Initial	Final	Initial	Final
Treatment	0.0844	0.1675	0.7879	0.6155
Depth	< 0.0001	< 0.0001	< 0.0001	< 0.0001
Time	< 0.0001	< 0.0001	< 0.0001	< 0.0001
Treatment x Depth	0.9606	0.4384	0.6305	0.0003
Treatment x Time	0.1194	0.0168	0.8762	0.0367
Depth x Time	< 0.0001	< 0.0001	< 0.0001	< 0.0001



The results clearly indicate that the designed treatment effect, i.e. unplanted vs. planted columns with two distinctly rooted species had a significant effect on the sensor readings during the final drainage experiment. As plants were cut just before starting the final drainage experiment they had no direct effect via transpiration. Therefore, the treatment effect is a consequence of hydraulic property differentiation between differently treated columns. This was not the case during the initial, pre-planting experiment as expected. Also the significant influence of depth and time were expected. Time simply represents different stages during the drainage process from wet to dry. The moisture state at depth is strongly

influenced by the distance to the lower boundary pressure. Thus, the residual inter-column variance due to sensor and filling effects was smaller compared to the different effects of interest in the experiments.

Fig. 10 above shows the TDR and tensiometer measurements during the initial and final drainage experiment. Displayed data confirm the statistical analyses discussed above. Induced by soil settlement over time and decreasing total porosity with depth saturated soil water content was higher at the beginning of the initial than for the final drainage experiment (very obvious in 40-50 and 50-60 cm depth).

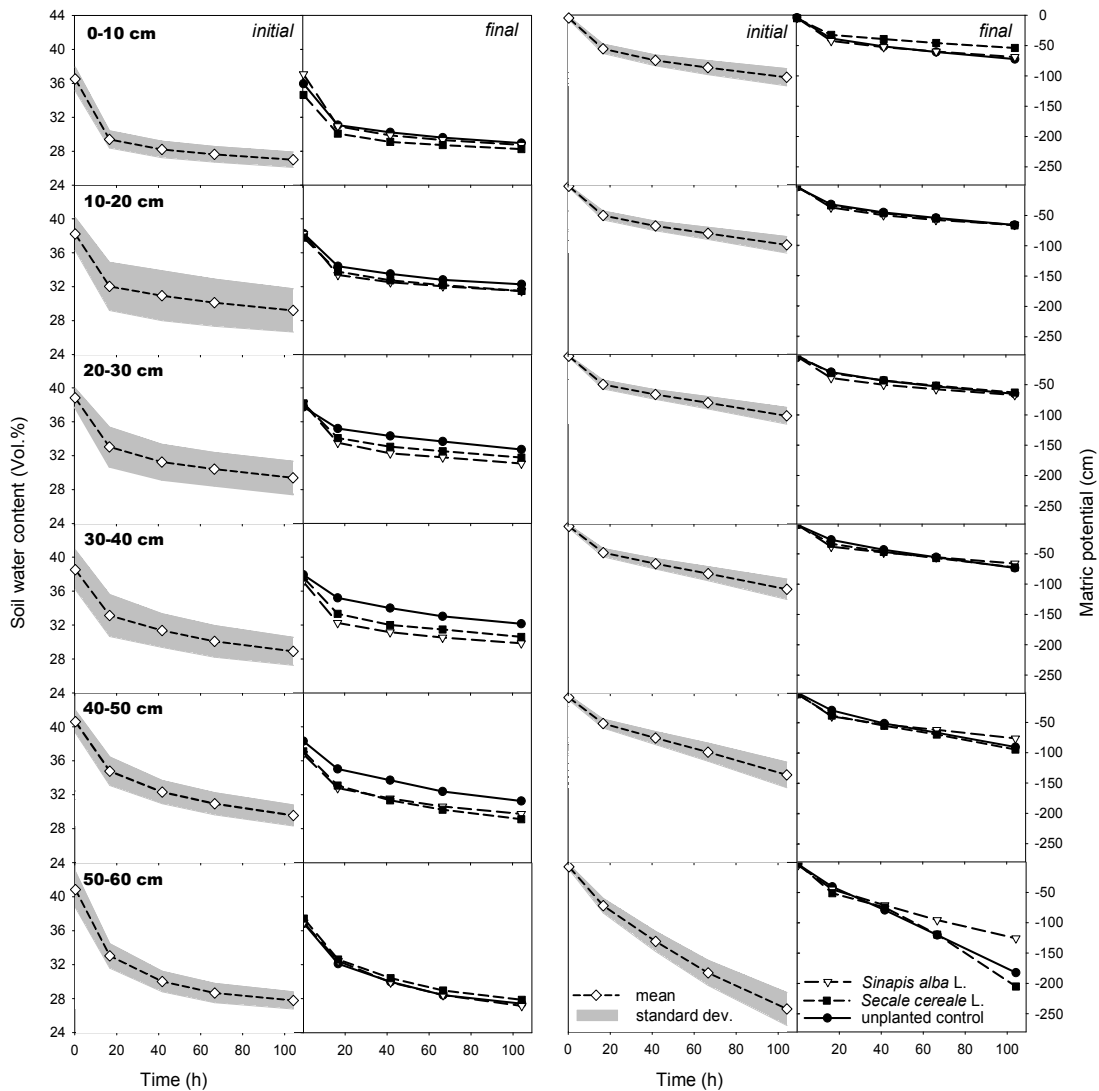

**Fig. 10. TDR and tensiometer readings at different moisture levels during the initial and final drainage experiment**

Treatment effects (planted vs. unplanted) due to changes in soil structure were significant. Occurring phenomena and processes are discussed in detail in Scholl et al. [31]. The highest range of moisture was obtained at the lowest layer (sensor depth = 55 cm) near the suction plate (e.g. mean values during initial drainage: 40.8 to 27.8 vol%). The hydraulic resistance of the soil reduced the applied boundary pressure head quickly and thereby the range of moisture changes during drainage. Still the range of pressure head we obtained was higher compared to other setups, e.g. Ritter et al. [25] stated a pressure head from saturation to -100 cm.

### 3.4 Further Potential Applications

The modular setup design allows an easy up or downgrade according to individual requirements. Technical limitations would be primarily driven by the recordable data amount. One reading procedure for the described setup with 12 columns and 144 soil water sensors took about 4:45 min. For a higher number of sensors, the reading intervals have to be adapted; especially delays due to errors or a reset of the system have to be considered. This limits the application of a multi-sensor setup for experiments that require monitoring water flow processes at very short time scales. Otherwise the experimental setup is suitable for a series of research topics of interest for soil hydraulics such as:

- *Short- and long-term changes of soil structural properties occurring on different time scales [40] and their effect on soil hydraulic behaviour.*
- *Altering irrigation and drainage phases can be applied to stimulate *wetting-drying cycles* and study their role for hydraulic property evolution.*
- *Soil hydraulic properties of *diverse substrates* (e.g. different soil textures, soil amendments) can be tested in combination with manifold irrigation schemes.*
- *The comparison of soil water balance components of different *plant species*, e.g. to study the interaction of plant physiology and soil hydrology.*
- *Different root systems (tap roots vs. fibrous roots) can be studied under controlled conditions focussing on *drought tolerance*.*
- *Chemical analysis of the collected bottom outflow in combination with fertilizer application to better understand *solute transport* and *nutrient turnover*.*

Additionally, pore water samplers can be installed. For studying *contaminant flow and uptake (phytoremediation)* an inclusion of suction cups in different depths could be of interest.

- *Tracer experiments* could be easily performed for different research objectives: Tracer (e.g. dye tracer, stable isotopes) can be applied by the automatic irrigation system.

## 4. CONCLUSION

We designed, tested and ran a laboratory setup in order to quantify root induced changes on soil hydraulic properties under controlled conditions. Inter-sensor variability of TDR-sensors and tensiometers amounted to 0.2 - 0.5 % and 1.2 - 4 %, respectively, i.e. any bias could be excluded for the replicated column setup. The developed Data Acquisition System (D.A.S.) enabled management of datasets derived from 144 sensors and related peripheral devices. The included semi-automatic trouble-shooting routine facilitated experiments running over long time spans such as for investigating plant effects on soil hydraulic properties; longest runtime we tested was eight months. Experimental factor evaluation confirmed that the setup is suitable to capture temporal changes of soil hydraulic properties, and thus to reveal soil settlement and root induced impacts. The provided data sets feature a high spatio-temporal resolution (six 10 cm layers per column, time steps  $\geq 5$  min) and fit the prerequisites for a subsequent inverse modelling of hydraulic property dynamics. For further applications the modular setup can be easily up or downgraded and is supposed to improve water flow and solute transport modelling by providing the data required for a dynamic description of soil hydraulic properties in simulation studies.

According to our investigations, we concluded that the introduced soil column setup is a reliable and promising tool to better understand the dynamic nature of soil hydraulic properties and the role of different biotic and abiotic drivers.

## ACKNOWLEDGEMENTS

This study was part of the project "Hydraulic effects of root-soil interactions" which was financially supported by the Austrian Science Fund (FWF), Project No. P 21836-B16. The authors are grateful for the financial support provided to their work. Warmest thanks to W.

Sokol (Institute of Hydraulics and Rural Water Management, University of Natural Resources and Life Sciences, Vienna) for his dedicated and skilled programming of “Bokerlom”. Special thanks to G. Buchan † (Centre for Soil and Environmental Quality, Lincoln University, New Zealand) for valuable comments and discussions during the initial stage of the project. We also thank the three anonymous reviewers for their valuable comments on the manuscript.

## COMPETING INTERESTS

Authors have declared that no competing interests exist.

## REFERENCES

- Gregory PJ. Plant roots: Growth, activity and interactions with soil. London: Blackwell Publishing Ltd.; 2006. ISBN: 10: 1-4051-1906-3
- Bengough AG. Water dynamics of the root zone: Rhizosphere biophysics and its control on soil hydrology. *Vadose Zone J.* 2012;11. DOI: 10.2136/vzj2011.0111.
- Logsdon SD. Root effects on soil properties and processes: Synthesis and future research needs. In: Timlin D, Ahuja LR, editors. *Enhancing understanding and quantification of soil-root growth interactions*. Madison: Soil Science Society of America; 2013. DOI: 10.2134/advagriscystmodel4.c8.
- Hillel D. *Introduction to environmental soil physics*. San Diego, California. USA. Elsevier Academic Press; 2004. ISBN: 10: 0-12-348655-6
- Scanlan CA. Processes and effects of root-induced changes to soil hydraulic properties. Dissertation, University of Western Australia; 2009.
- Głąb T, Szewczyk W. Influence of simulated traffic and roots of turf grass species on soil pore characteristics. *Geoderma.* 2014;230–231:221–228.
- Yuge K, Shigematsu K, Anan M, Yoshiyuki S. Effect of crop root on soil water retentivity and movement. *American Journal of Plant Sciences.* 2012;3: 1782-1787.
- Yunusa IAM, Newton PJ. Plants for amelioration of subsoil constraints and hydrological control: The primer-plant concept. *Plant Soil.* 2003;257:261–281.
- Deborah AL, Holtham G, Matthews P, Scholefield DS. Measurement and simulation of void structure and hydraulic changes caused by root-induced soil structuring under white clover compared to ryegrass. *Geoderma.* 2007;142:142–151.
- Mitchell AR, Ellsworth TR, Meek BD. Effect of root systems on preferential flow in swelling soil. *Commun Soil Sci Plant Anal.* 1995;26:2655–2666.
- Whalley WR, Riseley B, Leeds-Harrison PB, Bird NRA, Leech PK, Adderley WP. Structural differences between bulk and rhizosphere soil. *European Journal of Soil Science.* 2005;56:353–360. DOI: 10.1111/j.1365-2389.2004.00670.x.
- Steduto P, Hsiao TC, Raes D, Fereres E. AquaCrop-The FAO Crop Model to Simulate Yield Response to Water: I. Concepts and Underlying Principles. *Agron. J.* 2009;101:426-437. DOI: 10.2134/agronj2008.0139s.
- Raes D, Steduto P, Hsiao TC, Fereres E. Aqua Crop-The FAO Crop Model to Simulate Yield Response to Water: II. Main Algorithms and Software Description. *Agron. J.* 2009;101:438–447. DOI: 10.2134/agronj2008.0140s.
- Šimůnek J, Šejna M, Saito H, Sakai M, Van Genuchten MTh. The Hydrus-1D software package for simulating the movement of water, heat, and multiple solutes in variably saturated media, version 4.16, HYDRUS software series 3. Riverside: Department of environmental sciences. University of California riverside; 2013.
- Neitsch SL, Arnold JG, Kiniry JR, Williams JR. Soil and water assessment tool, theoretical documentation. (Version 2009). Texas water resources institute, technical report no. 406. Texas: Texas A&M University System; 2011.
- Hansen S, Abrahamsen P, Petersen CT, Styczen M. Daisy: Model use, calibration, and validation. *Trans. ASABE.* 2012;55(4): 1315-1333. DOI: 10.13031/2013.42244.
- Eberhardt LL, Thomas JM. Designing environmental field studies. *Ecological Monographs.* 1991;61(1):53-73.
- Bodner G, Scholl P, Loiskandl W, Kaul HP. Environmental and management influences on temporal variability of near saturated soil hydraulic properties. *Geoderma.* 2013;204:120-129.

19. Lawrence WJC. Techniques for experiments with pot plants. *Plant and Soil*. 1955;6(4):332-346.
20. Poorter H, Bühler J, Van Dusschoten D, Climent J, Postma JA. Pot size matters: A meta-analysis of the effects of rooting volume on plant growth. *Functional Plant Biology*. 2012a;39(11):839-850.
21. Poorter H, Fiorani F, Stitt M, Schurr U, Finck A, Gibon Y, et al. The art of growing plants for experimental purposes: A practical guide for the plant biologist. *Functional Plant Biology*. 2012b;39: 821–838.
22. Dane JH, Hruska S. *In-situ* determination of soil hydraulic properties during drainage. *Soil Science Society of America*. 1983; 47(4):619-624. DOI:10.2136/sssaj1983.03615995004700040001x.
23. Hopmans JW, Šimůnek J, Romano N, Durner W. Simultaneous determination of water transmission and retention properties - inverse methods. In: Dane JH, Topp GC, editors. *Methods of soil analysis, part 4, physical methods, 4<sup>th</sup> edition*. Soil Sci Soc Am. Book Ser 5. Madison. Soil Sci Soc Am; 2002.
24. Kosugi K, Inoue M. Estimation of hydraulic properties of vertically heterogeneous forest soil from transient matric pressure data. *Water Resour Res*. 2002;38:1322.
25. Ritter A, Muñoz-Carpena R, Regalado CM, Vancloster M, Lambot S. Analysis of alternative measurement strategies for the inverse optimization of the hydraulic properties of a volcanic soil. *J Hydrol*. 2004;295:124–139.
26. Loiskandl W, Buchan GD, Sokol W, Novak V, Himmelbauer M. Calibrating electromagnetic short soil water sensors. *J. Hydrol. Hydromech*. 2010;58(2): 114–125. DOI: 10.2478/v10098-010-0011-3.
27. Himmelbauer M, Loiskandl W, Klepsch S, Schnepf A. Application of TDR - Technique in Pot Experiments. In: European Geosciences Union. *Geophysical research abstracts*. EGU General Assembly; 2005. Vienna, Austria. 24.-29.4.2005. European Geosciences Union. 09325; 2005;7. SRef-ID: 1607-7962/gra/EGU05-A-09325
28. Twarakavi NKC, Saito H, Šimůnek J, Van Genuchten MTh. Inverse Modeling of vadose zone flow processes using squared  $\epsilon$ -insensitivity loss function. *J. Hydrol. Hydromech*. 2010;58(3):188-200.
29. Šimůnek J, De Vos JA. Inverse Optimization, calibration and validation of simulation models at the field scale. In: Feyen J, Wiyo K, editors. *Modelling of transport processes in soils at various scales in time and space; international workshop of EurAgEng's field of interest on soil and water*. Wageningen: Wageningen Pers; 1999.
30. Lazarovitch N, Ben-Gal A, Šimůnek J, Shani U. Uniqueness of soil hydraulic parameters determined by a combined wooding inverse approach. *Soil Sci. Soc. Am. J*. 2007;71:860–865. DOI: 10.2136/sssaj2005.0420.
31. Scholl P, Leitner D, Kammerer G, Loiskandl W, Kaul HP, Bodner G. Root induced changes of effective 1D hydraulic properties in a soil column. *Plant Soil*; 2014. DOI: 10.1007/s11104-014-2121-x.
32. Yang H, Rahardjo H, Wibawa B, Leong EC. A soil column apparatus for laboratory infiltration study. *Geotech Test J*. 2004;27: 347–355.
33. Dalton FN, Van Genuchten MTh. The Time-Domain Reflectometry Method for Measuring Soil Water Content and Salinity. *Geoderma*. 1986;38:237-250.
34. Malicki MA, Plagge R, Renger M, Walczak RT. Application of time-domain reflectometry (TDR) soil moisture miniprobe for the determination of unsaturated soil water characteristics from undisturbed soil cores. *Irrig Sci*. 1992;13: 65-72.
35. Plagge R, Renger M, Röth CH. A new laboratory method to quickly determine the unsaturated hydraulic conductivity of undisturbed soil cores within a wide range of textures. *Z. Pflanzenernaehr. Bodenk*. 1990;153:39–45. DOI: 10.1002/jpln.19901530109.
36. Skierucha W, Wilczek A, Walczak RT. Recent software improvements in moisture (TDR method), matric pressure, electrical conductivity and temperature meters of porous media. *Int. Agrophysics*. 2006;20: 229–235.
37. Evett SR, Schwartz RC, Casanova JJ, Heng LK. Soil water sensing for water balance, ET and WUE. *Agricultural Water Management*. 2012;104:1–9.

38. Rühle FA, Klier C, Stumpp C. Changes in water flow and solute transport pathways during long-term column experiments. *Vadose Zone J.* 2013;12(3). DOI: 10.2136/vzj2013.01.0032.
39. Piepho HP, Büchse A, Richter C. A mixed modelling approach for randomized experiments with repeated measures. *J Agron Crop Sci.* 2004;190:230–247.
40. Kay BD. Rates of change of soil structure under different cropping systems. *Adv. Soil Sci.* 1990;12:1–52.

---

© 2015 Scholl et al.; This is an Open Access article distributed under the terms of the Creative Commons Attribution License (<http://creativecommons.org/licenses/by/4.0>), which permits unrestricted use, distribution, and reproduction in any medium, provided the original work is properly cited.

*Peer-review history:*  
*The peer review history for this paper can be accessed here:*  
<http://sciencedomain.org/review-history/11623>